

150000 TRABA AUTOMATICA AMORTIGUADA

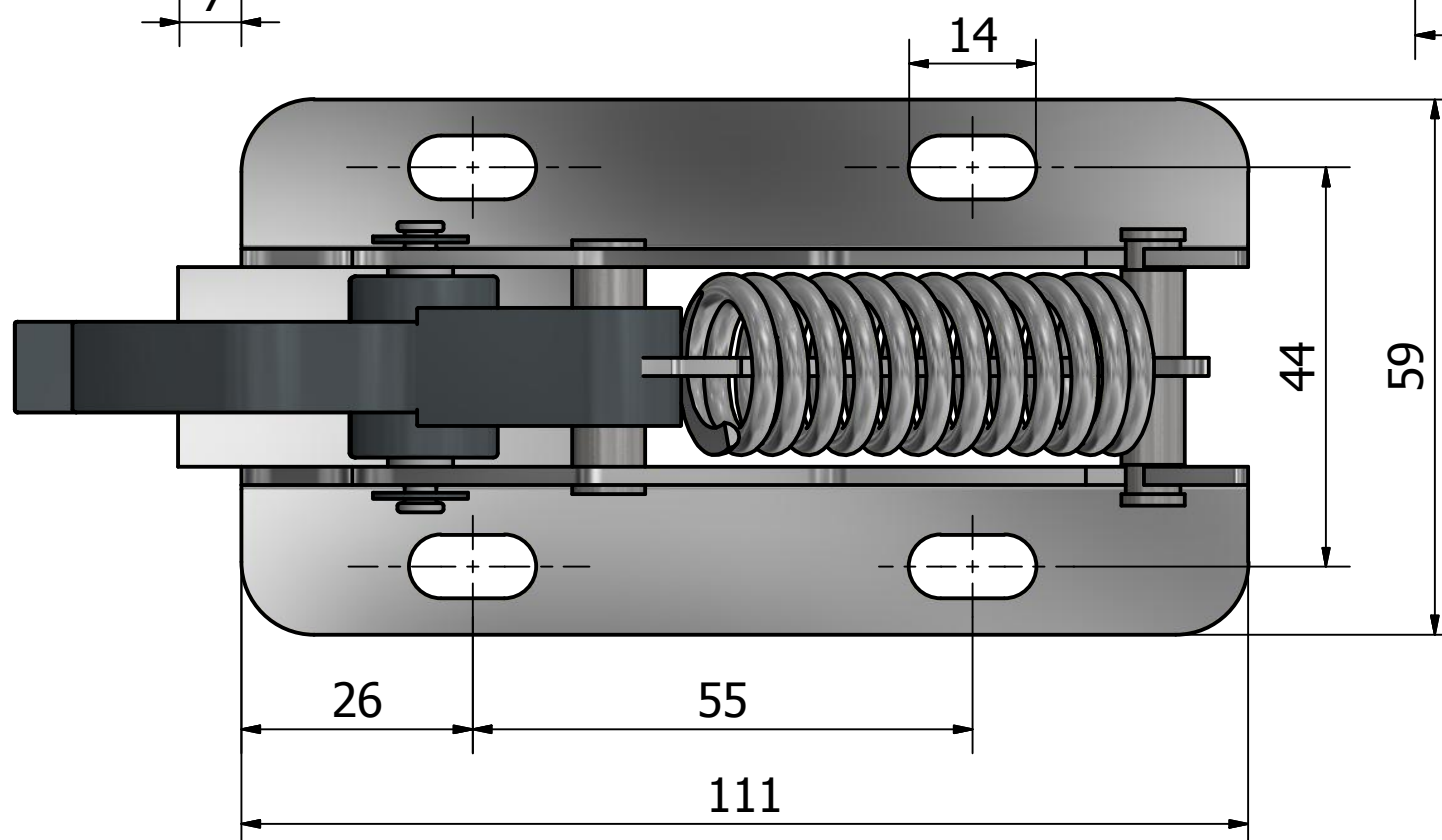
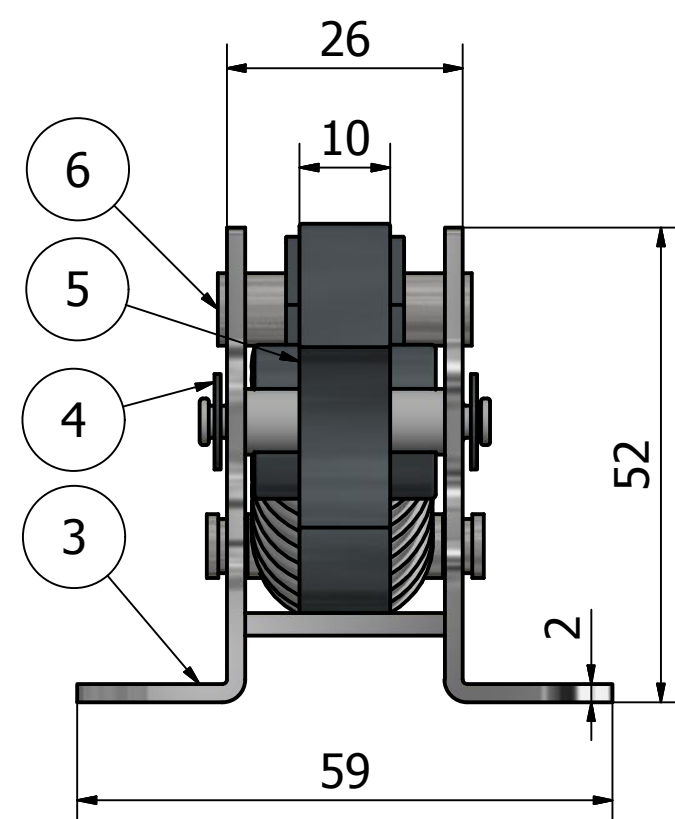
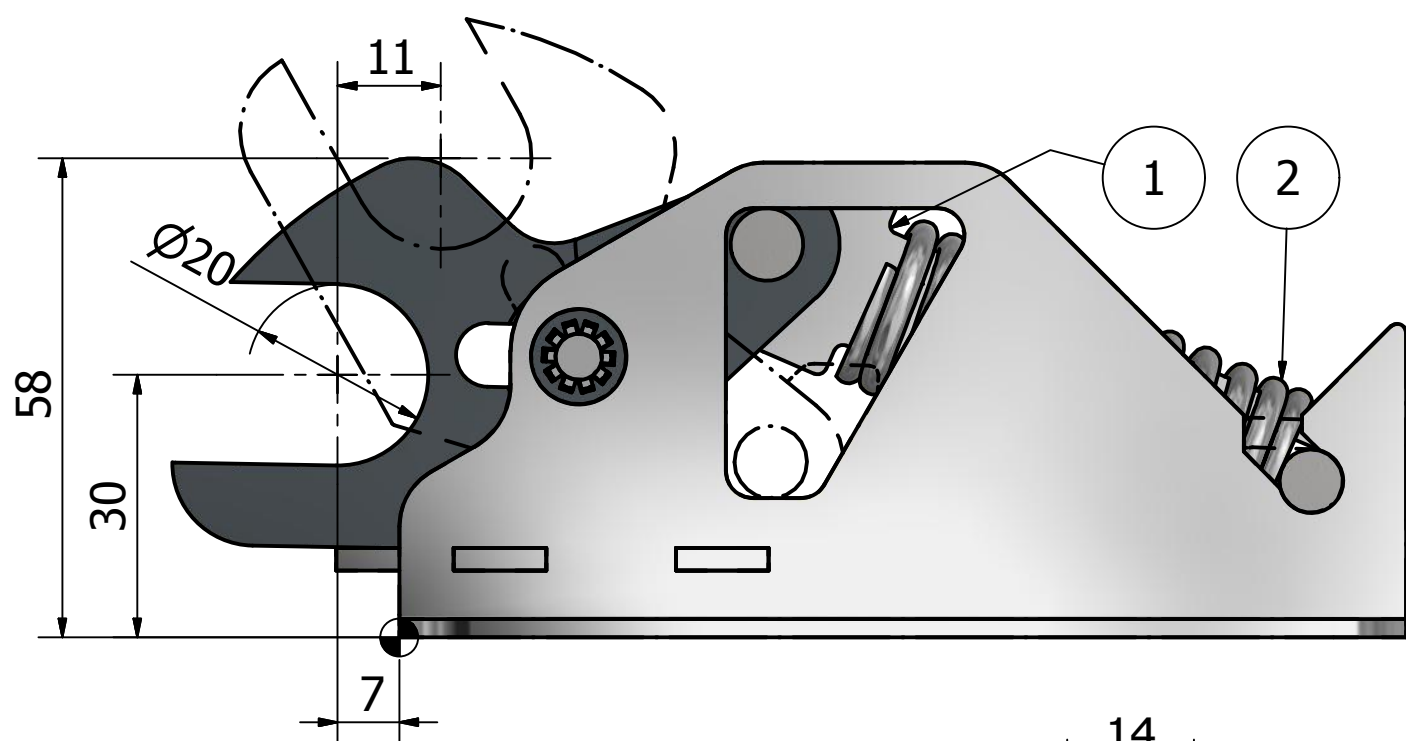
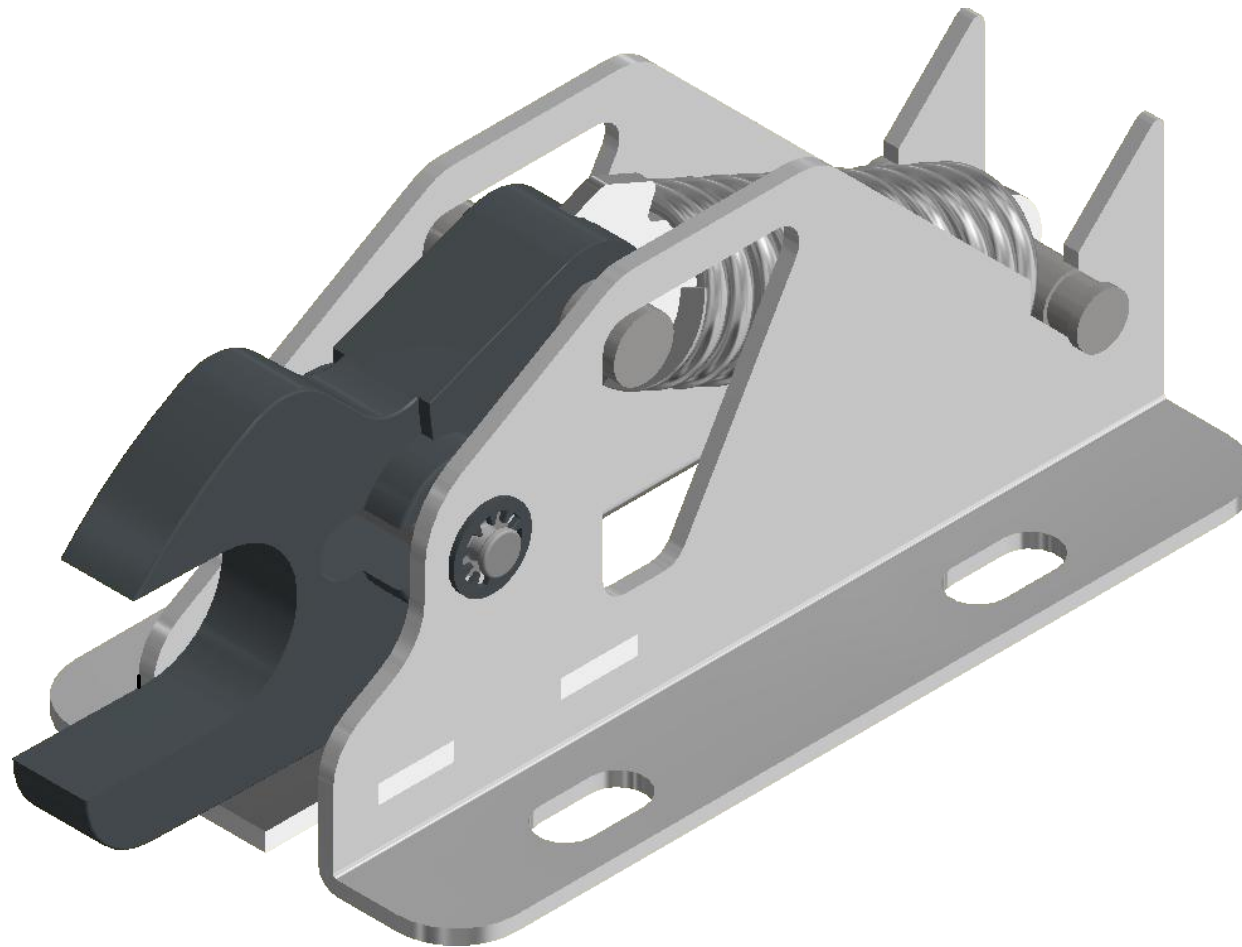

ITEM	Nº DE PIEZA	COLOR	MATERIAL
1	BIELA DE TRABA ANTIVIBRADOR	GLB	METAL
2	RESORTE TRABA	GLB	METAL
3	LAT. TRABA AUTOMATICA_MIR	GLB	METAL
4	ARANDELA DE PRESIÓN DIN 6797J	NEGRO	METAL
5	TRABA PLAST.	NEGRO	NYLON PA6
6	EJE OSCILANTE	GLB	METAL

APLICACION: Cierre rapido para tapas y puertas de acceso general, etc.